

Voith Turbo

VOITH

**Motor/pump hybrid system EPAI
for high and medium-pressure applications**

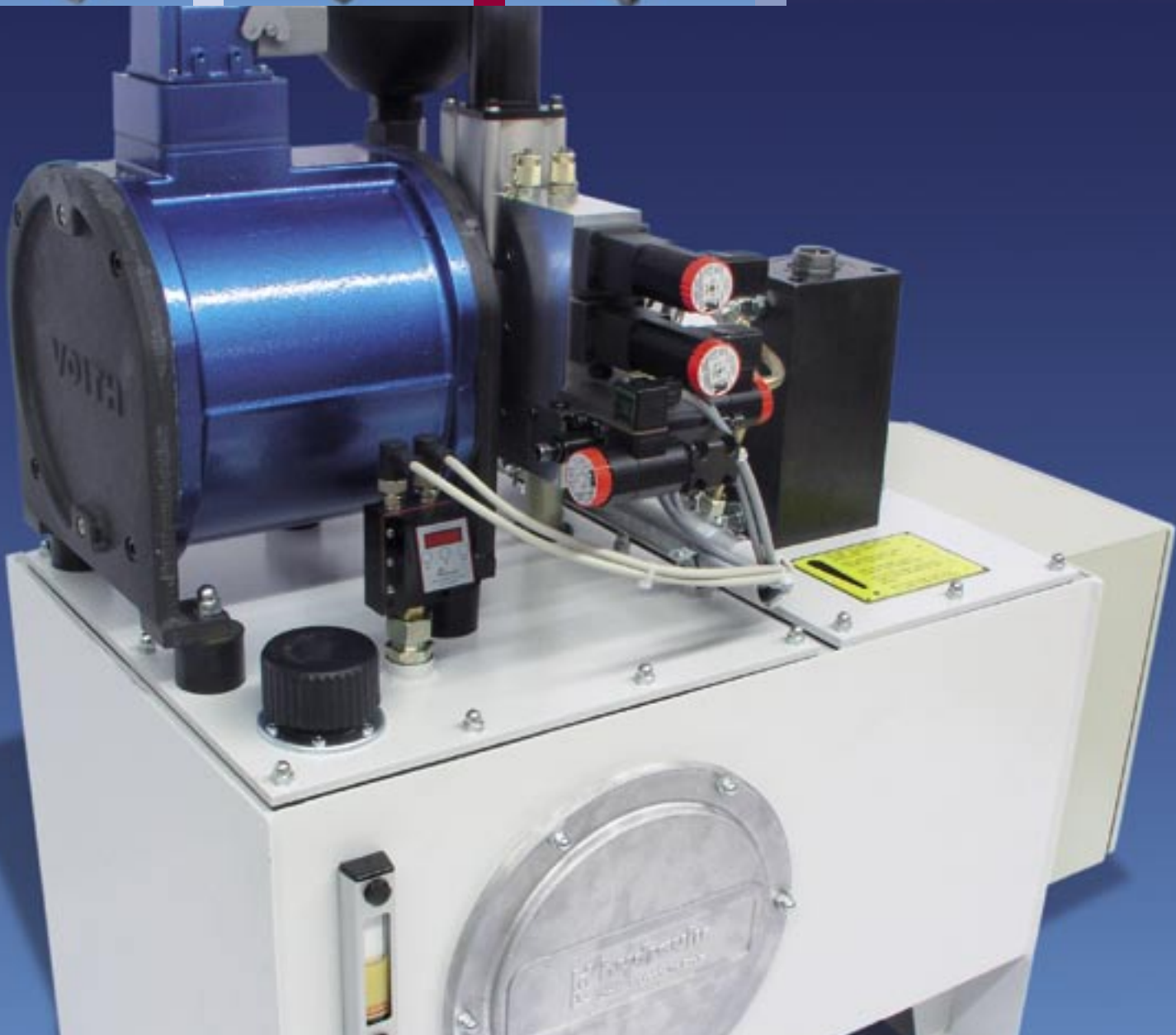

Two equals one: pump built into the motor

It sounds futuristic and yet, it is already a reality: Voith Turbo has managed to build the well-established internal gear pumps IPV (high pressure, up to 330 bar) and IPM (medium pressure, up to 175 bar) into an asynchronous electric motor. This allows us to offer you an electrohydraulic unit which is very compact in design while also ensuring remarkably low noise emissions.



EPAL system: internal gear pump built into asynchronous electric motor



Comparison of constructed size: up to 50% less space required

Features

- Continuous pressures up to 330 bar (IPV) or 175 bar (IPM)
- Asynchronous electric motor, 400V/3~
- Low noise levels, up to 12 dB(A) lower than the conventional motor/pump unit
- Compact design, up to 50% less space required than conventional solutions
- Very low flow and pressure pulsation
- Absence of dynamic sealing elements offers a high degree of protection against leaks
- Long service life expectancy and less maintenance through use of fewer wear parts
- Protection class IP 55, higher protection classes on request
- Designed with single or double pump
- Pressure relief and direction control valves can be attached (optional)
- Suitable for variable-speed drives (variable volume flow)

Applications

- Low-noise compact units, mainly in industrial applications
- Systems with limited space availability (shipbuilding, for example)
- Systems with demanding low-noise emission requirements (press construction or the plastics industry, for example)
- Areas where a high degree of freedom from leaks is required (the food industry, for example)
- Accumulator charging circuits

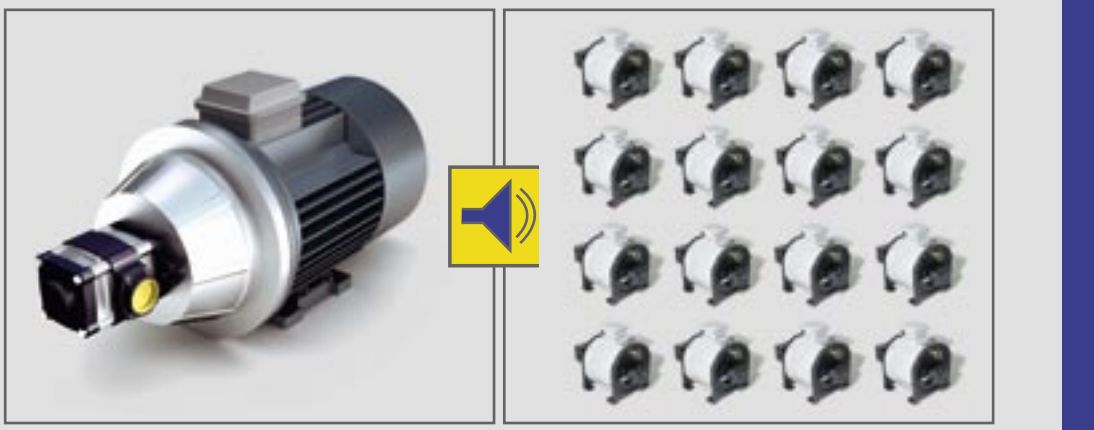

Noise emission: approx. 16 EPALs generate the noise level of a conventional piece of equipment

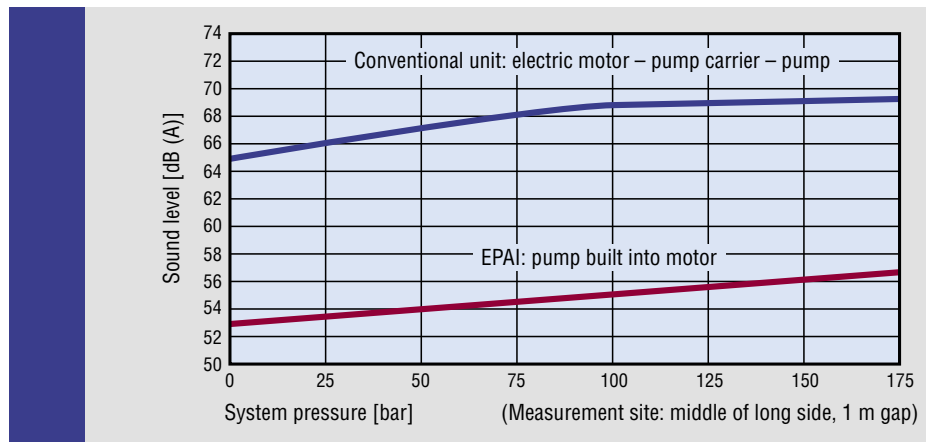

Sound level measurement: EPAL system with medium-pressure internal gear pump (7.5 kW) in comparison with a conventional piece of equipment (electric motor – bell housing – pump)

Performance data

Dimensions

Technical data – EPAI		
System	Design	Internal gear pump built into asynchronous electric motor
	Type	EPAI
	Mounting	See “Dimensions”
	Line mounting	Suction port: either SAE 1-¼ (SAE J 518 C Code 61) or thread G 1-¼ Pressure port: Thread G ½
	Rotation direction	Only operates in prescribed sense of rotation
	Mounting position	Horizontal
	Input pressure	0.8 to 3 bar absolute pressure (at start, briefly 0.6...3 bar)
	Pressure fluid	HLP mineral oils DIN 51524, part 2 or 3
	Viscosity range of the pressure fluid	10 to 100 mm ² s ⁻¹ (cSt)
	Permissible start viscosity	Max. 2000 mm ² s ⁻¹ (cSt)
	Permissible temperature of the pressure fluid in the intake	-20 to +65 °C
	Required purity of the pressure fluid according to NAS 1638	Class 8
	Filtration	Filtration with minimum retention rate of min. $\beta_{20} \geq 75$, recommended $\beta_{10} \geq 100$ (longer service life)
	Permissible ambient temperature	-10 to +60 °C
Motor	Rated voltage, rated frequency	400 V ± 10 %, 50 Hz ± 2 % or 460 V ± 10 %, 60 Hz ± 2 %
	Number of poles	4
	Type of protection	IP 55 in accordance with DIN 40050
	Cooling	Internal cooling with pressure fluid (hydraulic oil)
	Temperature protection	3 PTC thermistors, 100 °C

Typical characteristics of EPAI pumps

Pressure ranges	Type, size – delivery	Displacement per revolution	Delivery at 1 500 min ⁻¹	Continuous pressure	Peak pressure
		[cm ³]	[l/min]	[bar]	[bar]
Medium pressure	IPIM 4 – 6.5	6.7	10.1	175	210
	IPIM 4 – 8	8.2	12.3		
	IPIM 4 – 10	10.4	15.6		
	IPIM 4 – 13	13.1	19.7		
	IPIM 4 – 16	16.2	24.3		
	IPIM 4 – 20	20.1	30.2		
High pressure	IPIV 3 – 3.5	3.6	5.4	330	345
	IPIV 3 – 5	5.2	7.8		
	IPIV 3 – 6.3	6.4	9.6		
	IPIV 3 – 8	8.2	12.3		
	IPIV 3 – 10	10.2	15.3		

Typical characteristics of EPAI motors (50-Hz operation)

Type	Power rating	Rated current	Power factor cos φ	Rated motor torque M _N	Stalling torque M _K /M _N
	[kW]	[A]	–	[Nm]	–
HYDT160.11	3.0	8.2	0.80	19.8	3.7
	4.0	9.9	0.83	26.7	2.8
HYDT160.16	5.5	12.5	0.85	36.3	3.2
	7.5	16.2	0.88	50.2	2.3
HYDT160.24	9.0	19.0	0.89	59.7	2.9
	11.0	22.7	0.90	73.7	2.4

EPAI dimensions with single or double pump (in mm)

Motor type	L	L2	L3		
HYDT160.11	255	173	340		
HYDT160.16	280	198	365		
HYDT160.24	320	238	405		

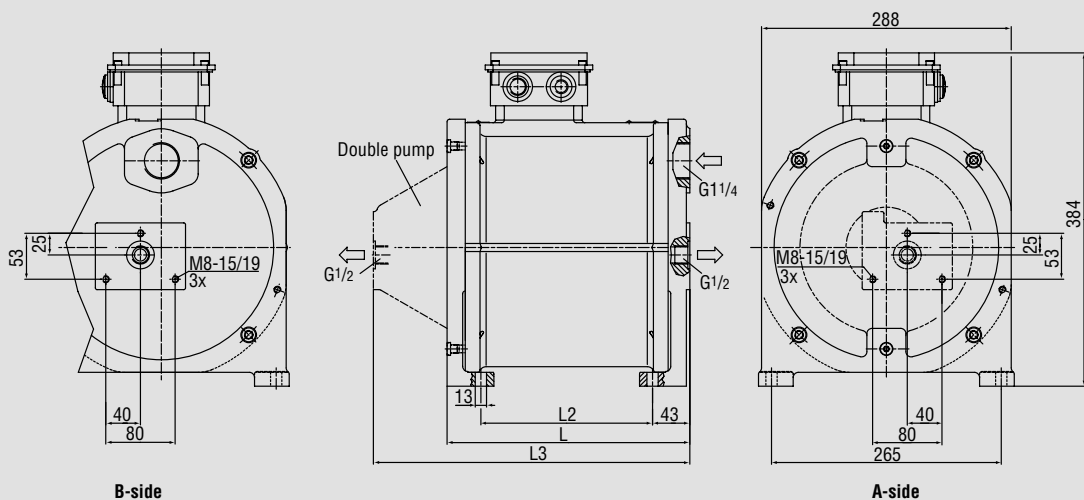

Selection/combinations of motor and pump

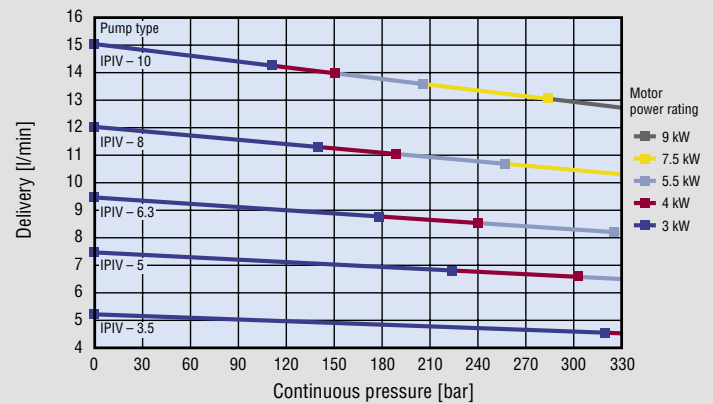
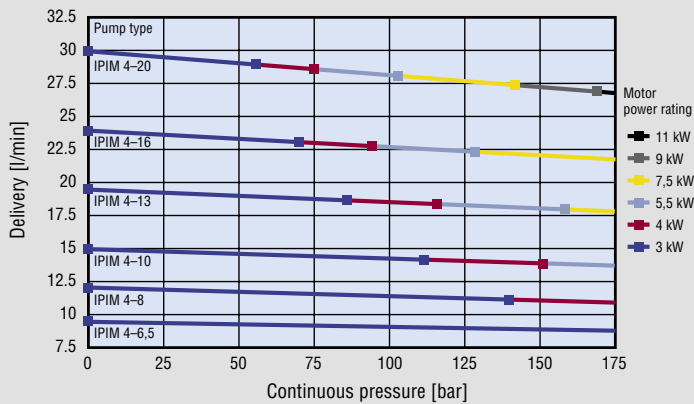

Medium-pressure motor/pump combinations (n = 1500 min⁻¹)

High-pressure motor/pump combinations (n = 1500 min⁻¹)

The above diagrams will help you to select the optimal motor/pump combination for a single pump. For the more complex double-pump applications, please feel free to contact your Voith Turbo representative.

Type code – order designation

Type	Motor power rating [kW]	Direction of terminal box	Direction of cable connection	Pump type B-side	Pump type A-side (only in double pumps)	Suction port	Assembly valves	Special designs	
EPAI	3	T Top	R Right	IM... IPIM...	IM... IPIM...	G SAE	X No valve block VBA Valve block on A-side VBB Valve block on B-side	S... Special voltage, plug, ex-protection etc.	
	4	L Left	L Left	IV... IPIV...	IV... IPIV...				
	5.5	R Right		(see page 5)	(see page 5)				
	7.5								
	9								
	11								
Example	EPAI-4-TR-IM4-16-IM4-6.5-G-VBB								
	Standard								

Design and function - EPAI hybrid system

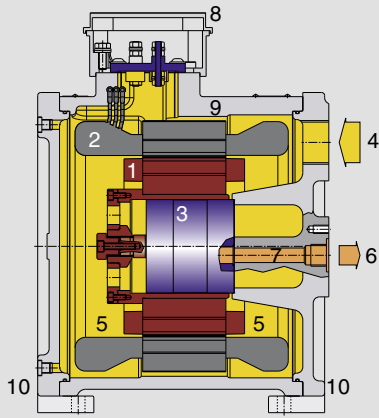

EPAI with single pump

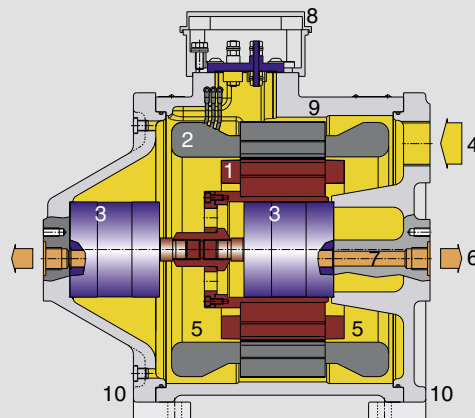

EPAI with double pump

1. Rotor
2. Stator
3. Internal gear pump
4. Suction port
5. Suction chamber
6. Pressure port
7. Pressure chamber
8. Terminal box
9. Housing
10. Cover

Unit

- Compact, quiet, electro-hydraulic
- Voith internal gear pump built into asynchronous electric motor
- Available in single or double-pump design
- Pressure relief valves can be attached (optional) and system can be set up for further valves
- Variable volume flow can be generated with frequency converter

Motor

- Inexpensive, low-maintenance squirrel-cage asynchronous motor
- Internal cooling with pressure fluid
- Robust design
- Easy to operate
- No shaft end leading outside

Pump

- Well-established Voith Turbo internal gear pump with all its advantages
- Long service life
- Low-maintenance

Mechanical structure

- Motor housing with cast-iron feet
- Radially supported rotor with plain bearing to ensure quiet running. No axial bearing. The centering effect provided by the magnetic forces provide axial guidance.
- Rotatable housing – this means the terminal box can be assembled on the top, right or left

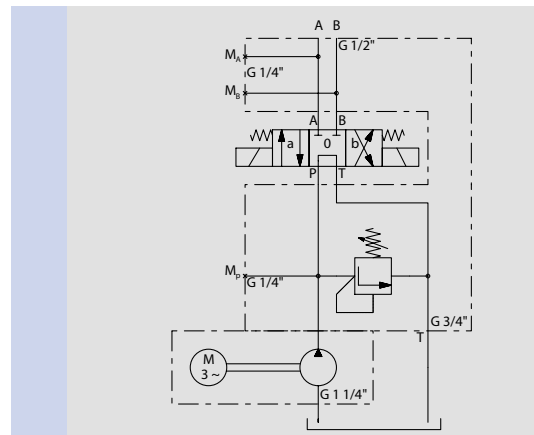

*Example of a hydraulic circuit diagram:
Single pump with valve block*

Voith Turbo GmbH & Co. KG
Hydrostatics
Alexanderstr. 2
89522 Heidenheim, Germany
Tel. +49 7321 37-4573
Fax +49 7321 37-7809
hydrostatik@voith.com
www.voithturbo.com/hydrostatics.htm

VOITH
Engineered reliability.